

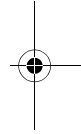

# Clarke®

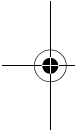

## WORKBENCH

MODEL NO: CWB1700P

PART NO: 4501510

## OPERATION & MAINTENANCE INSTRUCTIONS

LS1119

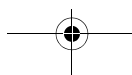
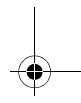
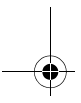



---

## INTRODUCTION

---

Thank you for purchasing this CLARKE WorkBench.

Before attempting to use this product, please read this manual thoroughly and follow the instructions carefully. In doing so you will ensure the safety of yourself and that of others around you, and you can look forward to your purchase giving you long and satisfactory service.

---

## GUARANTEE

---

This product is guaranteed against faulty manufacture for a period of 12 months from the date of purchase. Please keep your receipt which will be required as proof of purchase.

This guarantee is invalid if the product is found to have been abused or tampered with in any way, or not used for the purpose for which it was intended.

Faulty goods should be returned to their place of purchase, no product can be returned to us without prior permission.

This guarantee does not effect your statutory rights.

---

## SPECIFICATIONS

---

Model Number	CWB1700P
Part Number	4501510
Weight	72 kg
Dimensions (L x W x H)	1700 x 600 x 850 mm

---

## SAFETY NOTICE

---

**PLEASE NOTE THAT DUE TO THE WEIGHT OF THIS PRODUCT, IT IS RECOMMENDED THAT TWO PEOPLE LIFT IT IN TO POSITION.**

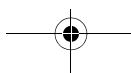

## CARTON CONTENTS

The following items should be supplied in the carton. If any parts are missing or damaged, please see your CLARKE dealer where you purchased the workbench.

Left Leg	Drawer Slide (Type A) x 4	Drawer Bottom x 5
Middle Leg	Drawer Slide (Type B) x 3	Shelf x 1
Right Leg	Drawer Slide (Type C) x 3	Door x 1
Upper Panel	Foot x 6	Door Lock x 1
Lower Panel	Drawer Front x 5	Rear Angle Bracket x 1
Divider	Drawer Side x 10	Front Angle Bracket x 1
Rear Panel	Drawer Back x 5	Bag of Nuts /Bolts and Washers

## DRAWER SLIDE IDENTIFICATION

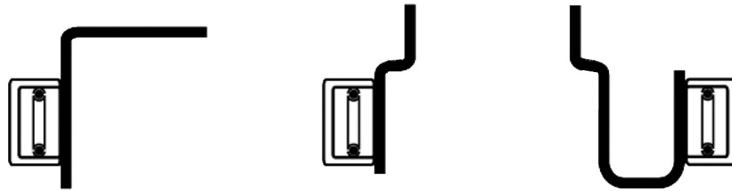

TYPE 'A'

TYPE 'B'

TYPE 'C'

1. There are three types of drawer slide supplied 4 x Type 'A', 3 x Type 'B' and 3 x Type 'C'

## ASSEMBLE THE DRAWERS

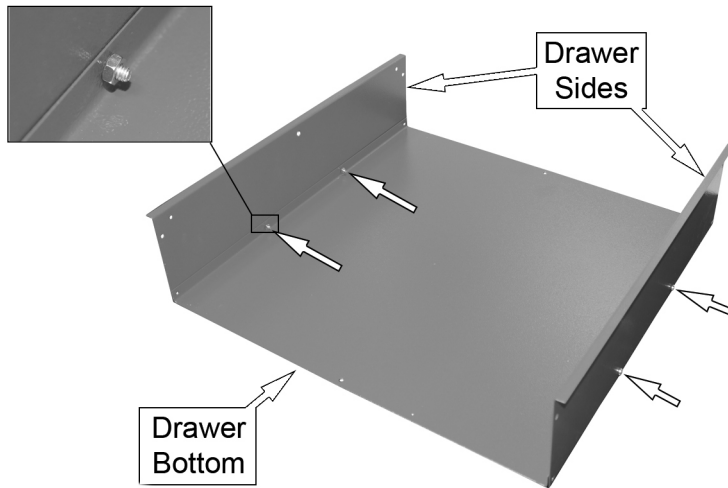

1. Fit the drawer sides to the drawer bottom as shown and use two M4x8 bolts, washers and nuts in the central 2 holes to secure in place.

**NOTE:** The nuts and washers must be fitted to the inside of the drawer.

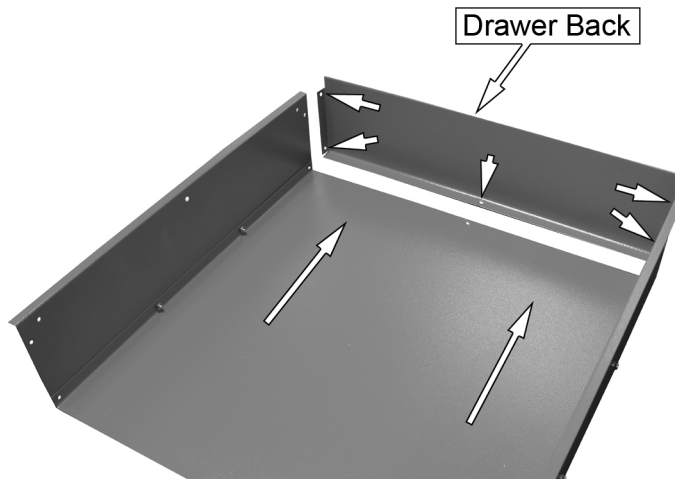

2. Connect the drawer back to the assembly as shown using 5 M4x8 Bolts, washers and nuts.

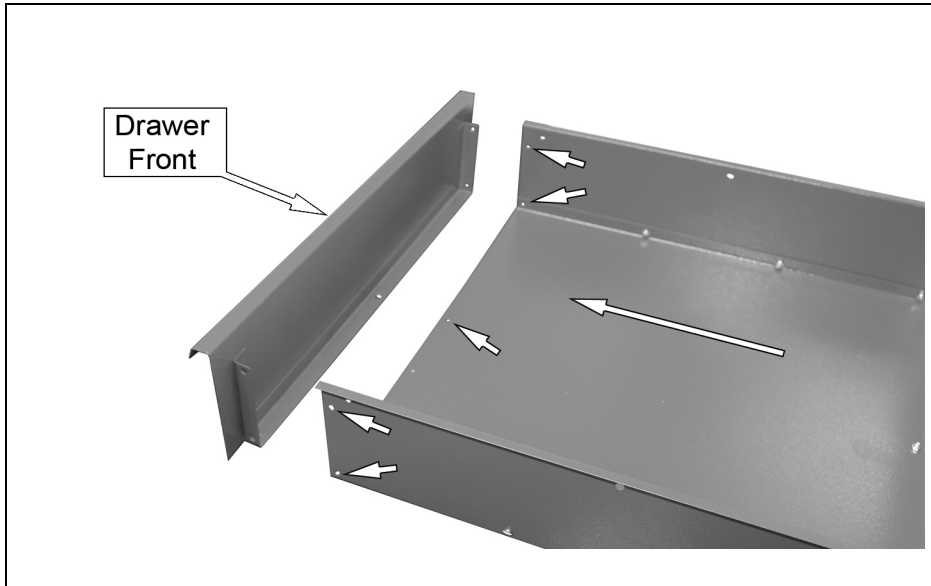

3. Connect the drawer front to the assembly as shown using 5 M4x8 Bolts, washers and nuts.
4. Repeat steps 1-3 for the remaining four drawers, giving you a total of five drawers

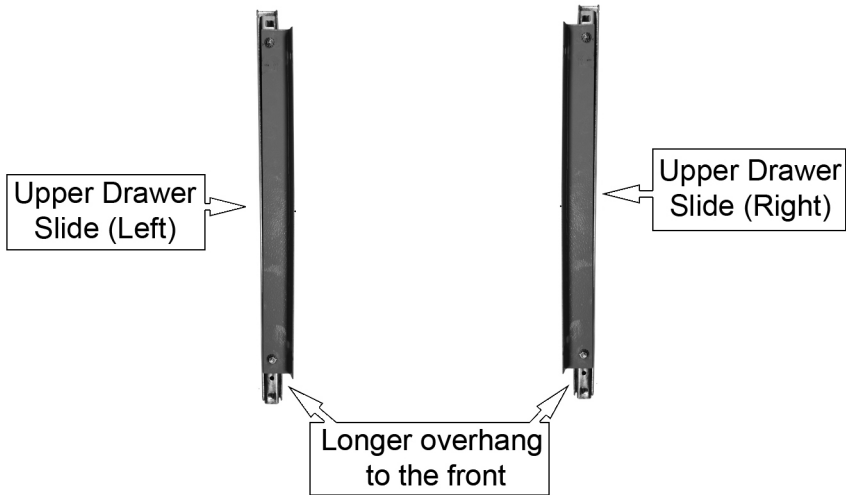

5. Locate the 4 upper drawer slides Type 'A' there should be two left and two right.

Upper Drawer  
Slide (Left)

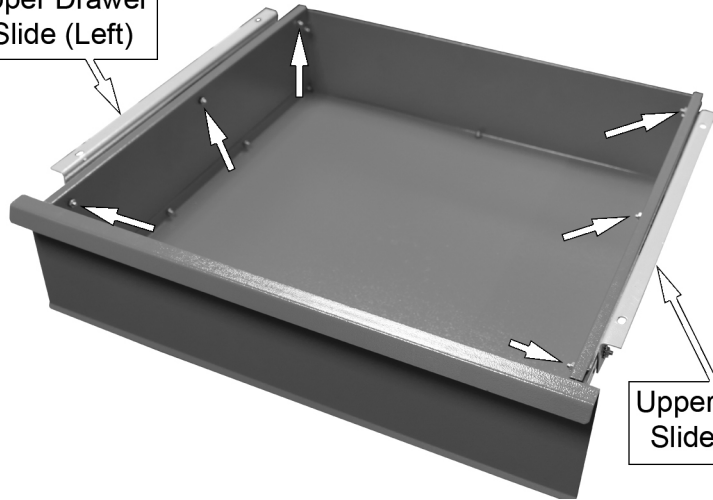

Upper Drawer  
Slide (Right)

6. Fit the drawer slides (Type 'A') to two of the drawers as follows

- Extend the drawer slide by hand
- Line up the drawer slide with the top of the drawer as shown.
- Secure each slide using three M4 screws, washers and nuts,

**NOTE:** The nuts and washers must be fitted to the inside of the drawer.

**Place all drawers to one side for now, you will fit them later.**

## ASSEMBLE THE MAIN FRAME

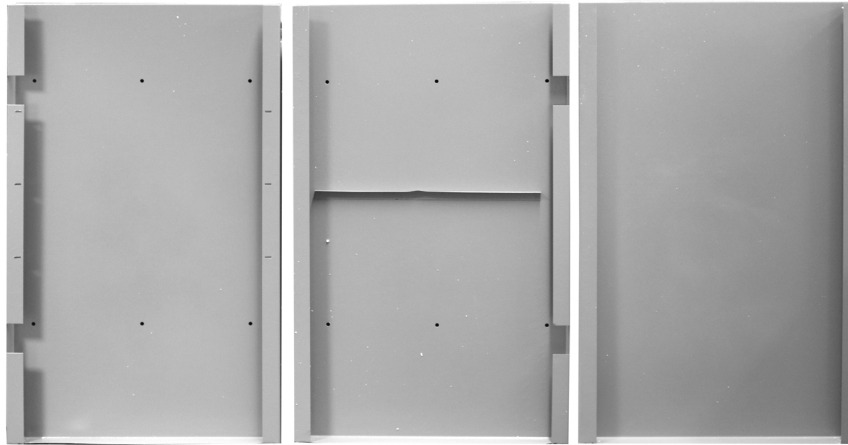

Left

Middle

Right

1. Locate and identify the three legs as shown.

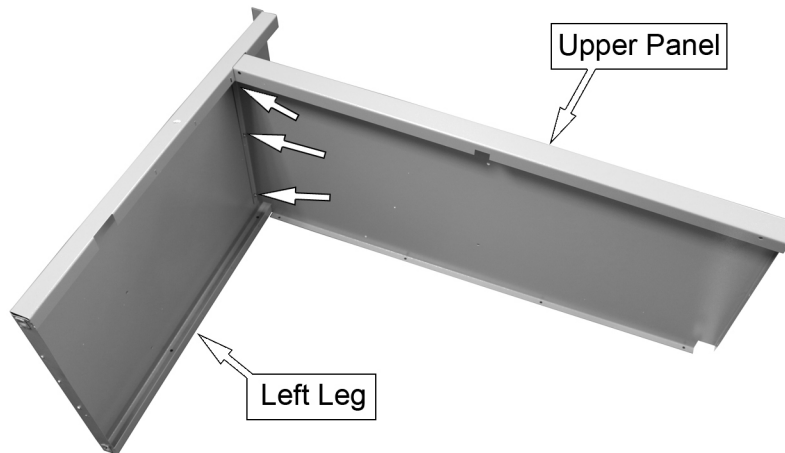

2. Connect the upper panel to the left leg as shown using 3 M5x8 Bolts, washers and nuts.

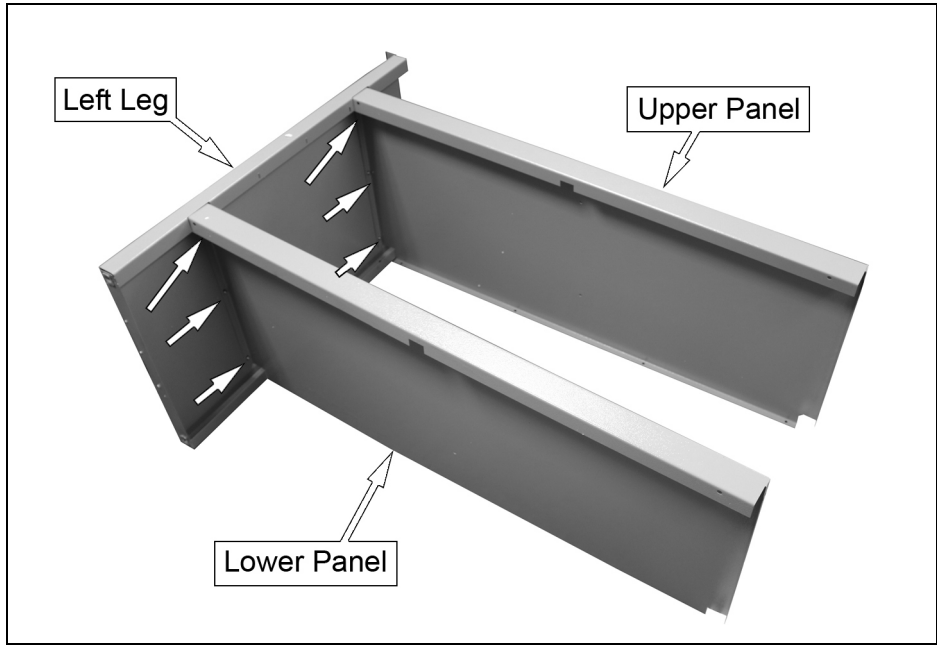

3. Connect the lower panel to the left leg as shown using 3 M5x8 Bolts, washers and nuts.

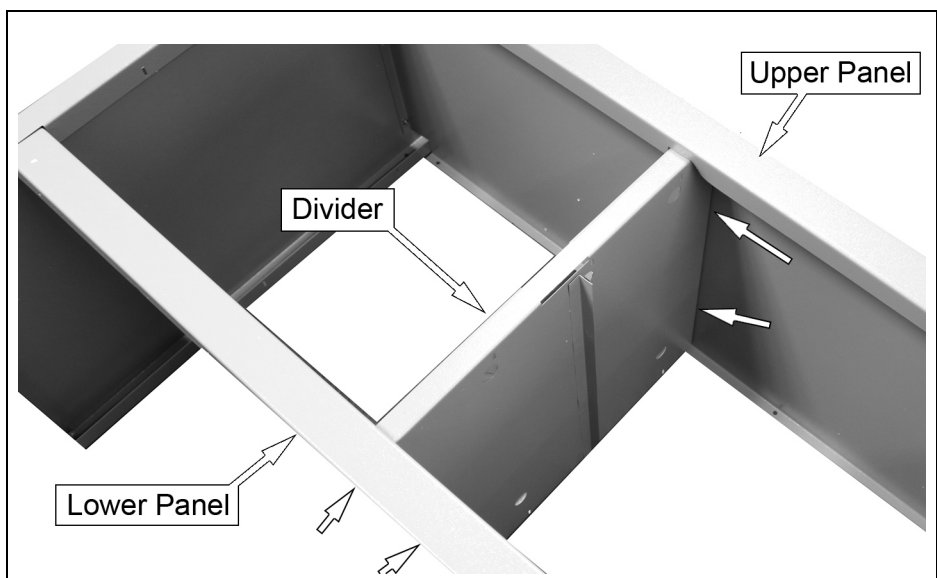

4. Fit the divider between the upper and lower panels using 4 M5x8 Bolts, washers and nuts.

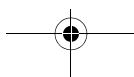



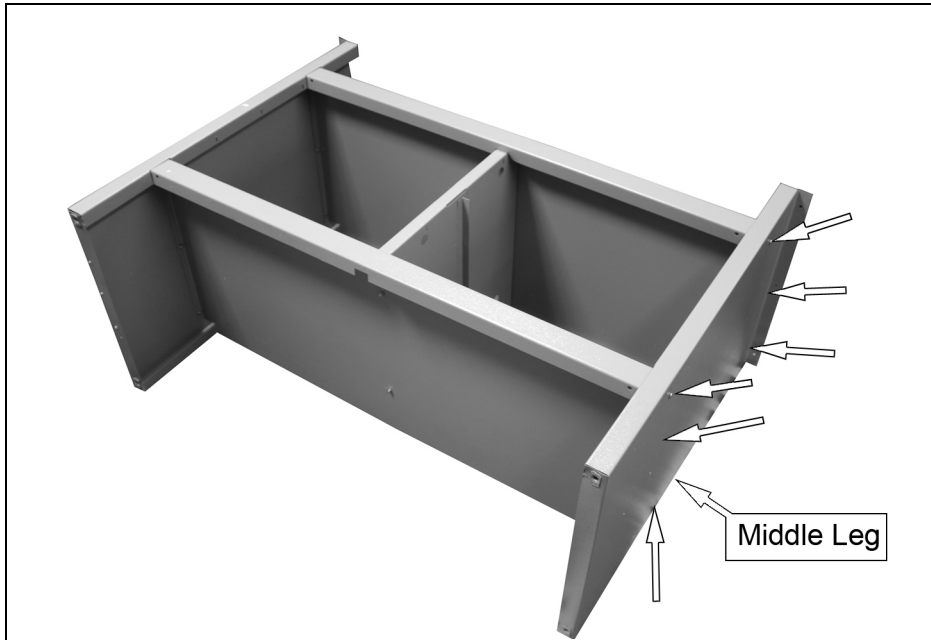

5. Connect the middle leg to the upper and lower panels as shown using 6 M5x8 Bolts, washers and nuts.

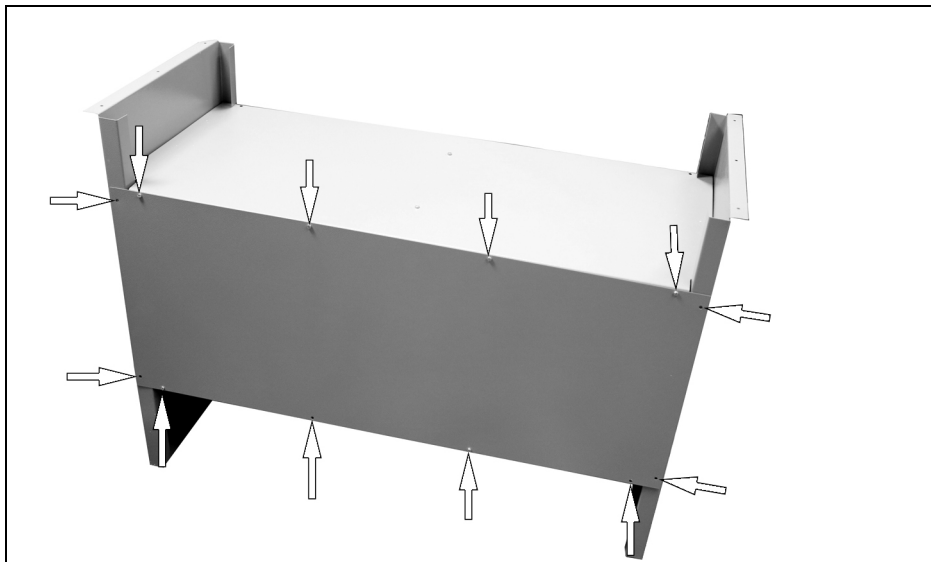

6. Carefully stand the workbench up and fit the back panel as shown using 12 M5x8 Bolts, washers and nuts.

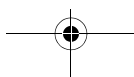

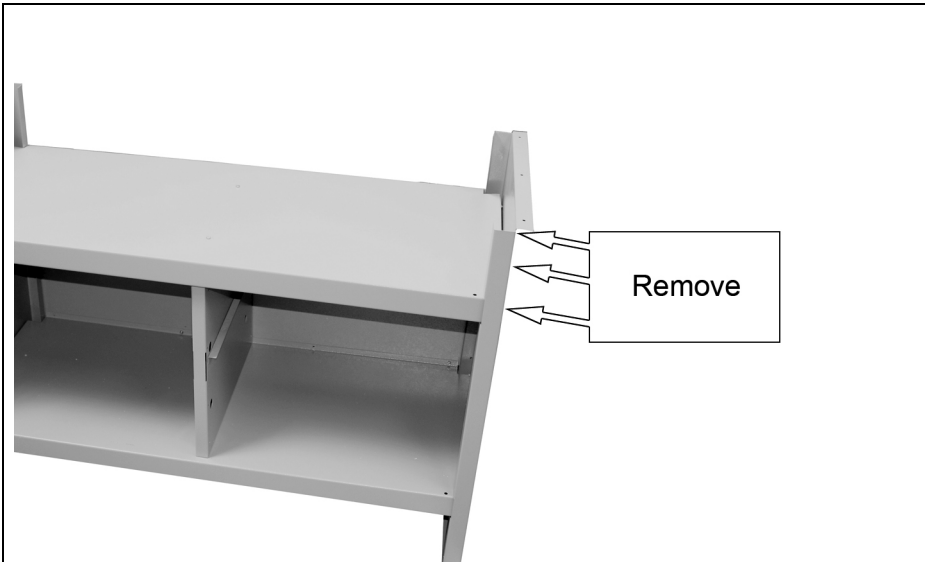

7. Remove the 3 M5x8 Bolts, washers and nuts that connect the middle leg to the upper panel, this is nessecery to enable you to fit the door.

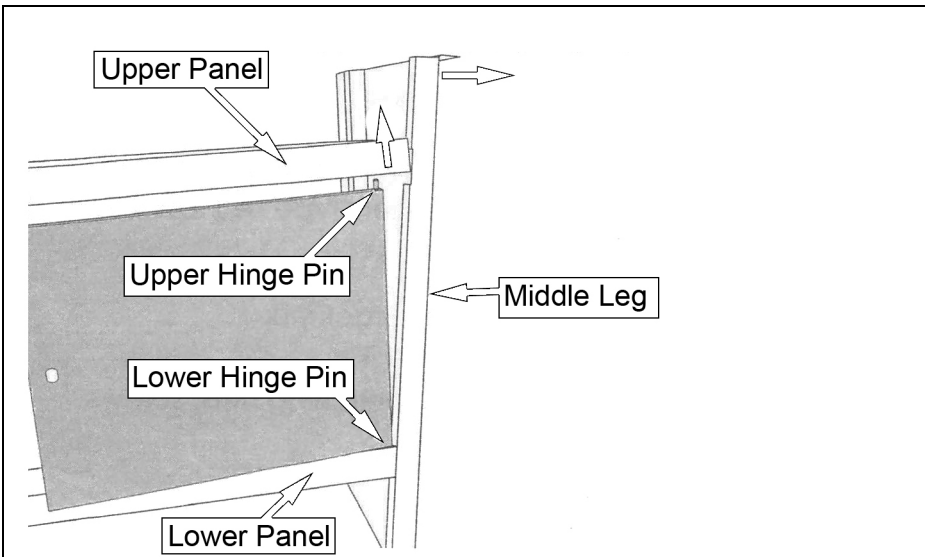

8. Fit the door as shown and then replace the 3 M5x8 Bolts, washers and nuts that you removed in the previous step.

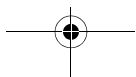
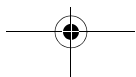



9. Place the shelf into position.

10. Tighten up all the nuts and bolts.

11. Fit the adjustable feet to the bottom of the legs including the right leg which will be fitted later.

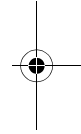
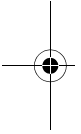

## FITTING THE TOP AND RIGHT LEG

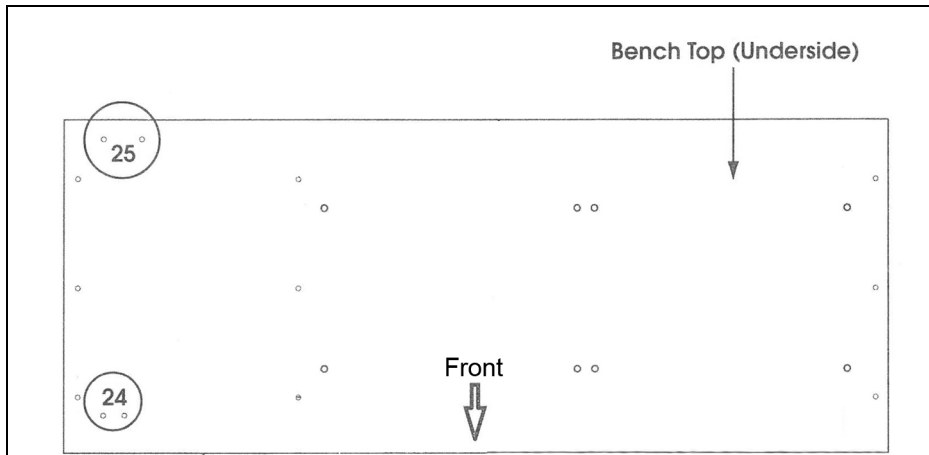

1. Lay the top upside down on the frame with the front towards you.

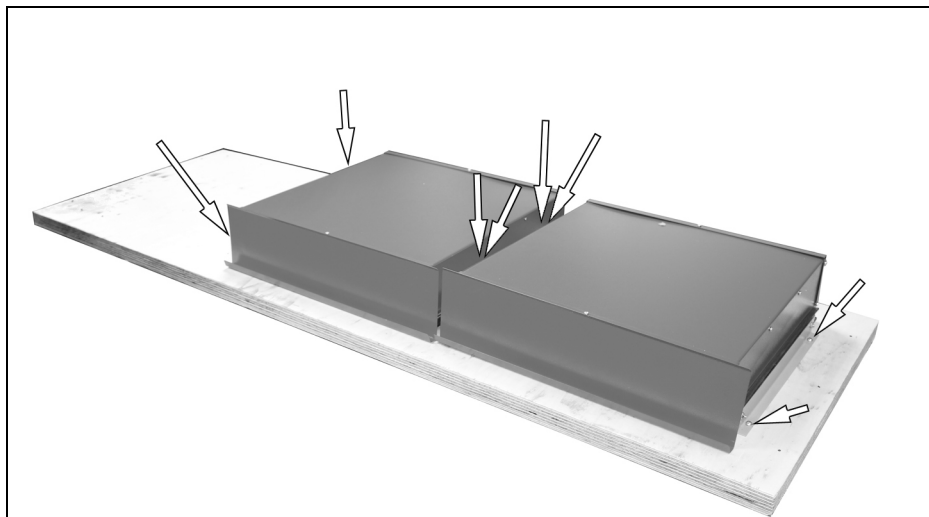

2. Lay the two completed drawers (with slides fitted on page 6) into position and secure using 8 wood screws supplied.



3. With assistance, flip the top over and into position as shown
4. Secure to the frame with 6 wood screws.

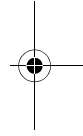
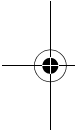

5. Place the right leg into position and secure with 3 wood screws.

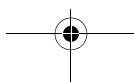
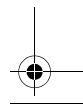
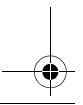

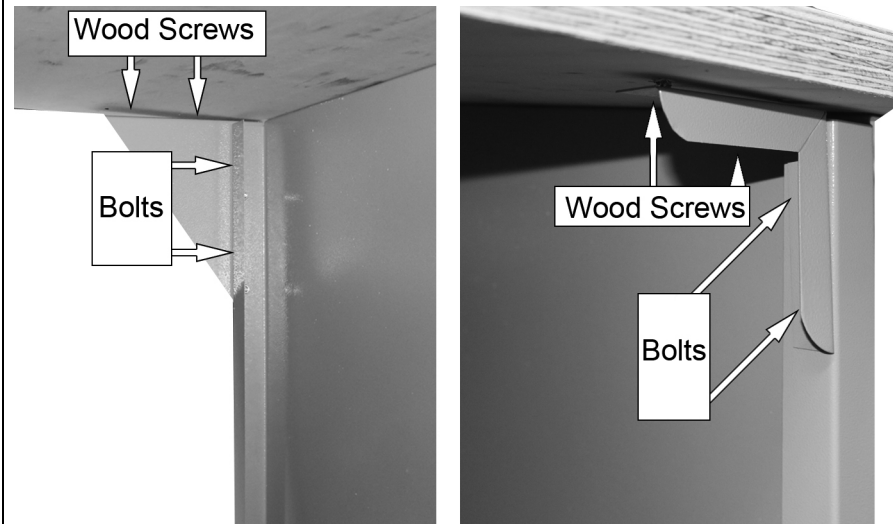

6. Fit the support brackets as shown using wood screws and M5x8 bolts, washers and nuts
  - The larger bracket is fitted to the rear of the bench

## FITTING DOOR LOCK

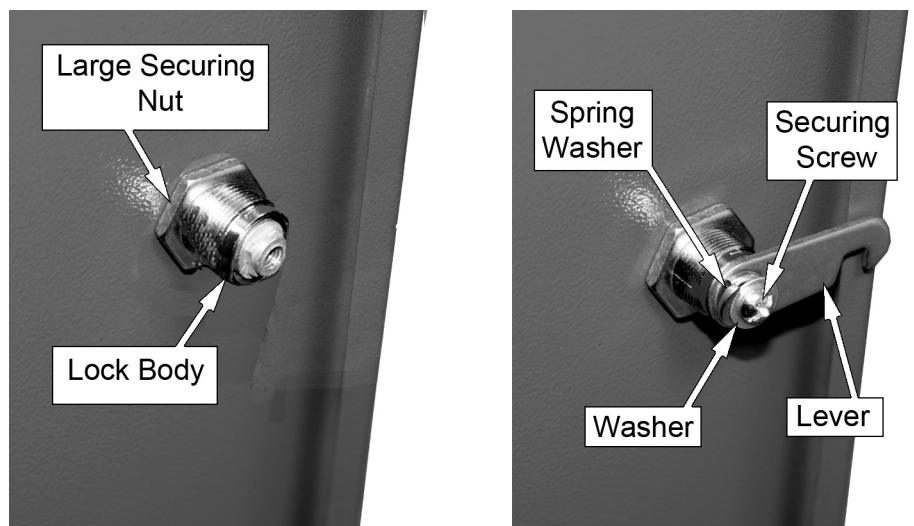

**IMPORTANT: Ensure the key remains in the lock until lock is fully fitted.**

1. Remove the locking lever securing screw and lock washer from the lock assembly, remove the lever, spring washer and washer noting which way round they are fitted for reassembly.
  - Take care to ensure the barrel does not fall out of the lock body.
2. Unscrew and remove the large securing nut, insert the lock into the hole in the door, refit the large securing nut and tighten with spanner,
  - DO NOT overtighten.
3. Turn the key fully anticlockwise (locked position), fit the lever as shown
4. Secure the lever with the spring washer, washer and securing screw.
5. Check that the lock works properly i.e. anticlockwise = locked and clockwise = unlocked.

## FITTING THE LOWER DRAWERS

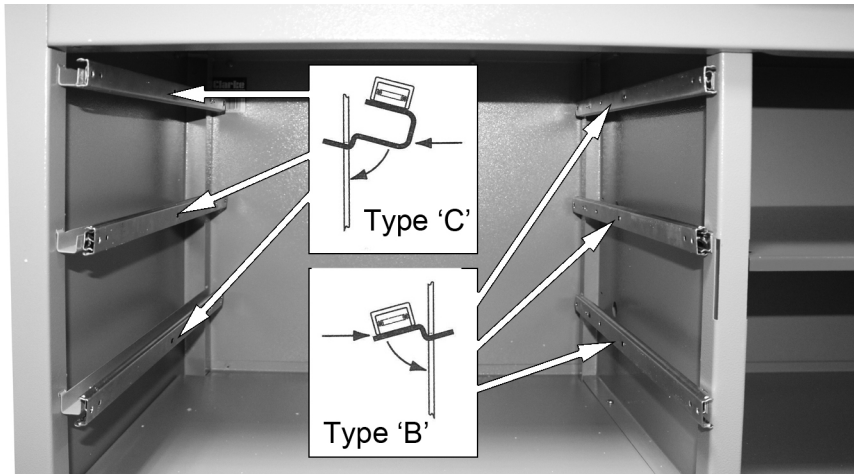

1. Insert the tongues into the slots on the legs and allow the drawer slide to swing down and rest on the leg, no fixings are required



2. Starting with the bottom drawer, pull out the drawer slides as far as possible.
3. Lay the drawer into position as shown and secure each slide to the drawer using countersunk screws, washers and nuts,





4. Make sure that you tighten all bolts and screws
5. Before using the bench for the first time, we recommend the application of a waterproof wood preservative to the bench top to prevent staining from oil spills etc.
6. The bench is now ready to use.

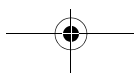
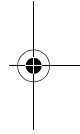
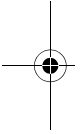

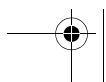
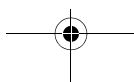
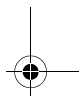
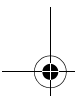
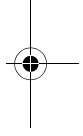
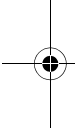
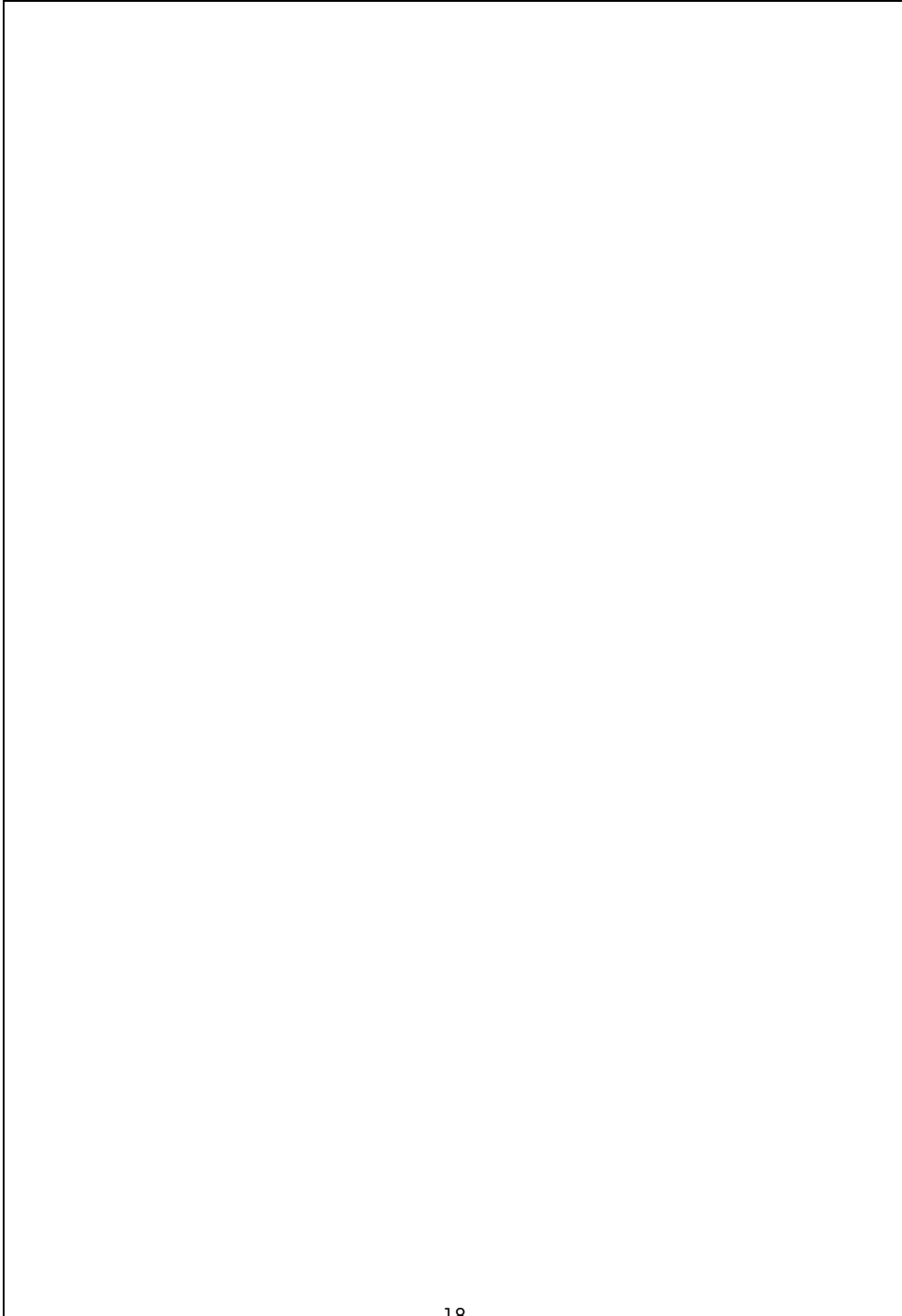
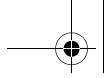

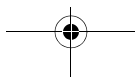
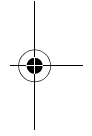
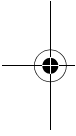
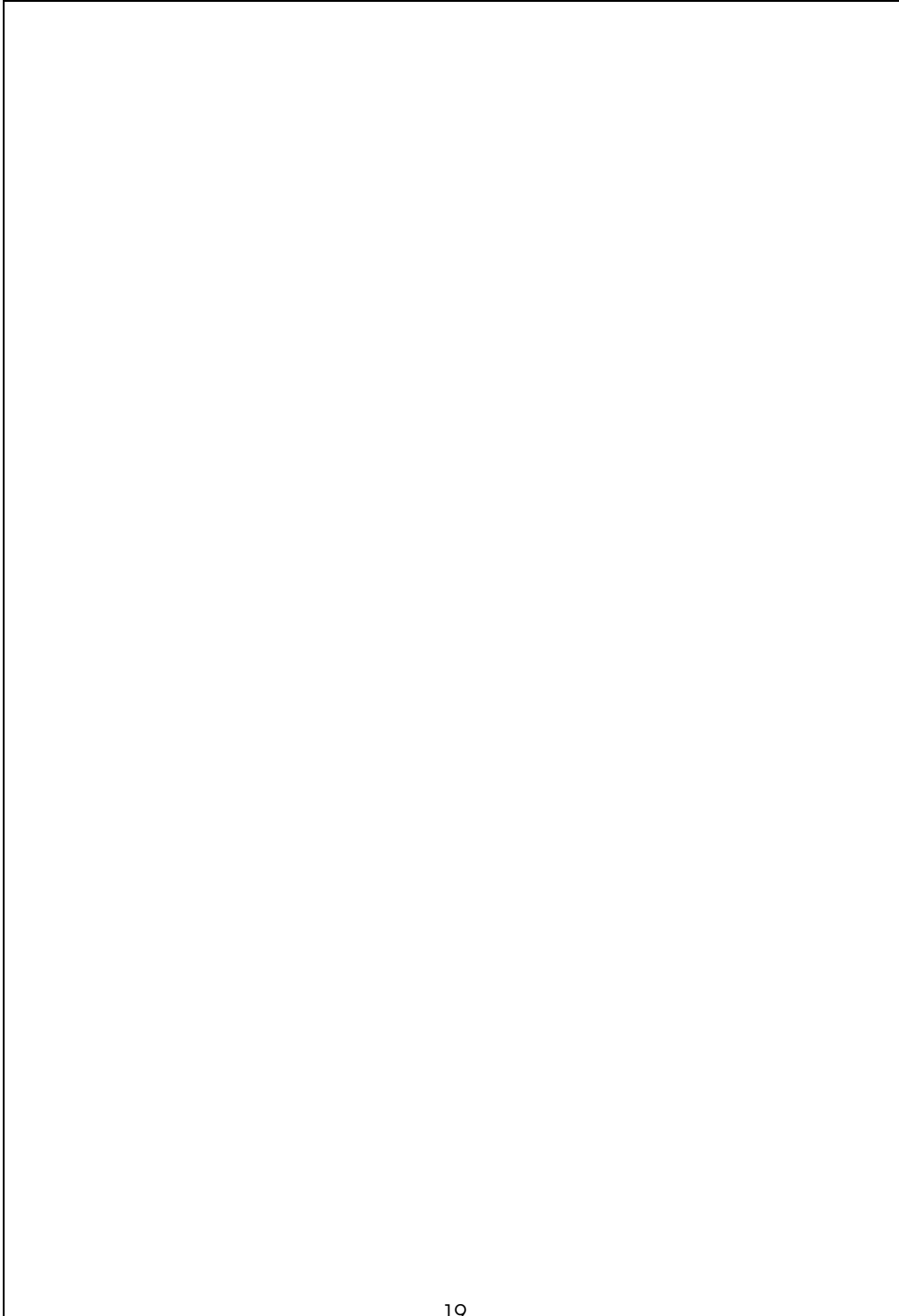

## A SELECTION FROM THE VAST RANGE OF

# Clarke®

## QUALITY PRODUCTS



**AIR COMPRESSORS**  
From DIY to industrial, Plus air tools, spray guns and accessories.

**GENERATORS**  
Prime duty or emergency standby for business, home and leisure.

**POWER WASHERS**  
Hot and cold, electric and engine driven - we have what you need

**WELDERS**  
Mig, Arc, Tig and Spot. From DIY to auto/industrial.

**METALWORKING**  
Drills, grinders and saws for DIY and professional use.

**WOODWORKING**  
Saws, sanders, lathes, mortisers and dust extraction.

**HYDRAULICS**  
Cranes, body repair kits, transmission jacks for all types of workshop use.

**WATER PUMPS**  
Submersible, electric and engine driven for DIY, agriculture and industry.

**POWERTOOLS**  
Angle grinders, cordless drill sets, saws and sanders.

**STARTERS/CHARGERS**  
All sizes for car and commercial use.



**PARTS & SERVICE: 0208 988 7400**

**E-mail: [Parts@clarkeinternational.com](mailto:Parts@clarkeinternational.com) or [Service@clarkeinternational.com](mailto:Service@clarkeinternational.com)**

**SALES: UK 01992 565333 or Export 00 44 (0)1992 565335**

**Clarke** INTERNATIONAL Hemnall Street, Epping, Essex CM16 4LG  
[www.clarkeinternational.com](http://www.clarkeinternational.com)